



Handbrake
product manual

**Congratulations on acquiring this Heusinkveld®
Handbrake.** We hope you will enjoy this top-of-the-line
racing simulator product for many years to come.

Introduction

This is the manual for the Heusinkveld® Handbrake. We advise you to read it thoroughly in order to get the most enjoyment out of this product.

Table of contents

This manual has the following main sections:

- Introduction
- Initial setup
- Mechanical adjustments
- Smartcontrol adjustments
- Maintenance
- CE Declaration of Conformity

Packing list

The box contains the following:

- Handbrake
- Adapter plate

Accessory box, which contains:

- USB cable
- Hex key tool
- Elastomer springs
- Mounting materials
- Manual

Version

This manual version is: November 24, 2025.

Digital download

The current version of the Quick Start manual can be downloaded at: heusinkveld.com/downloads/

Contact

If you have any questions which are not covered in this manual, feel free to send us an email at support@heusinkveld.com.

Initial setup

In this section we'll explain how to mount the Heusinkveld® Handbrake to your rig and make fine adjustments to the setup.

Mounting materials

A selection of bolts, nuts and T-nuts is included with your handbrake. These will in many cases be sufficient to create a solid mount between your simulator, the handbrake and the optional adapter plate.

Please note that there is a great variety of simulator platforms available and we cannot foresee every possible mounting scenario. We can therefore not rule out that you may need to source some mounting materials yourself.

Overall position of the handbrake

Before starting the installation, determine the overall position of the handbrake which works best on your simulator.

Take the following into account:

- The **base** can be mounted in a horizontal or vertical position.

- The **lever** can be mounted in a horizontal or vertical position (relative to the base).

Changing the orientation of the lever

By default the lever is in a horizontal position. The lever can be reassembled to a vertical position relative to the base of the handbrake.

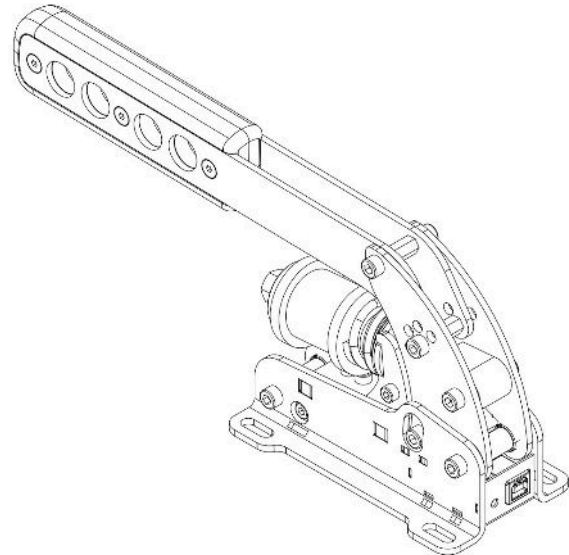

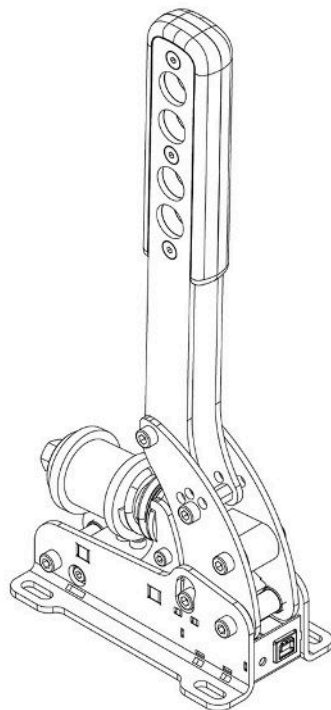
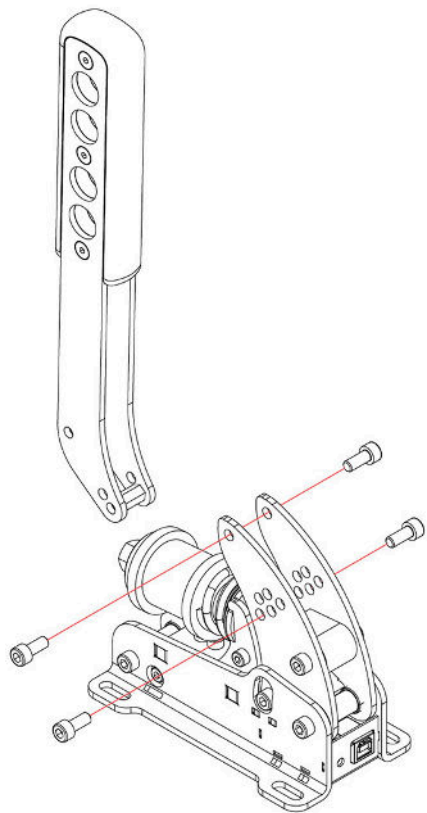

Mounting the handbrake to your simulator

If you have determined the general position of the handbrake, you can decide on how to mount the handbrake to the simulator. There are 2 options for mounting the handbrake to your simulator:

- 1) Using the 4 holes on each corner of the base to mount the handbrake directly to your simulator.
- 2) Using the adapter plate as a mounting platform between the handbrake and your simulator.

The adapter plate can be mounted with 2 bolts and t-nuts to an aluminium profile. The 4 holes on each corner of the handbrake match the pre-tapped corner holes of the adapter plate. No nuts are needed here.

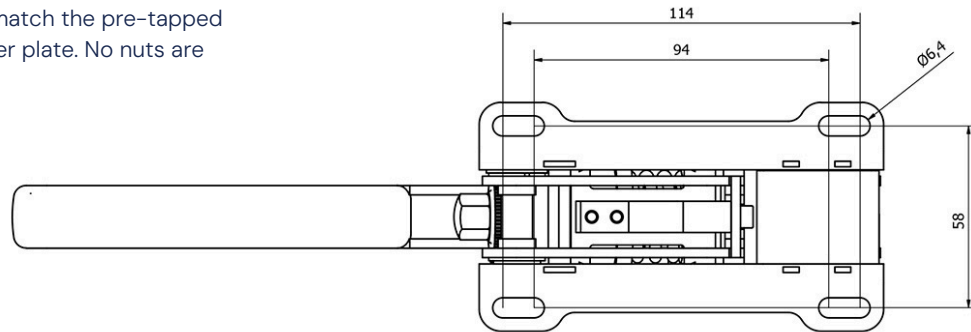
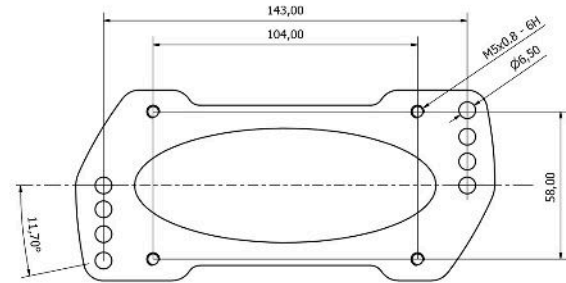

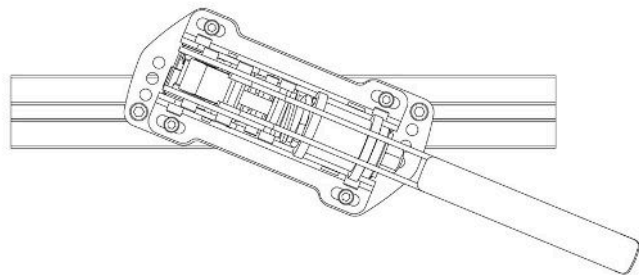
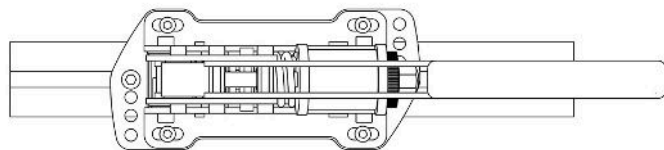
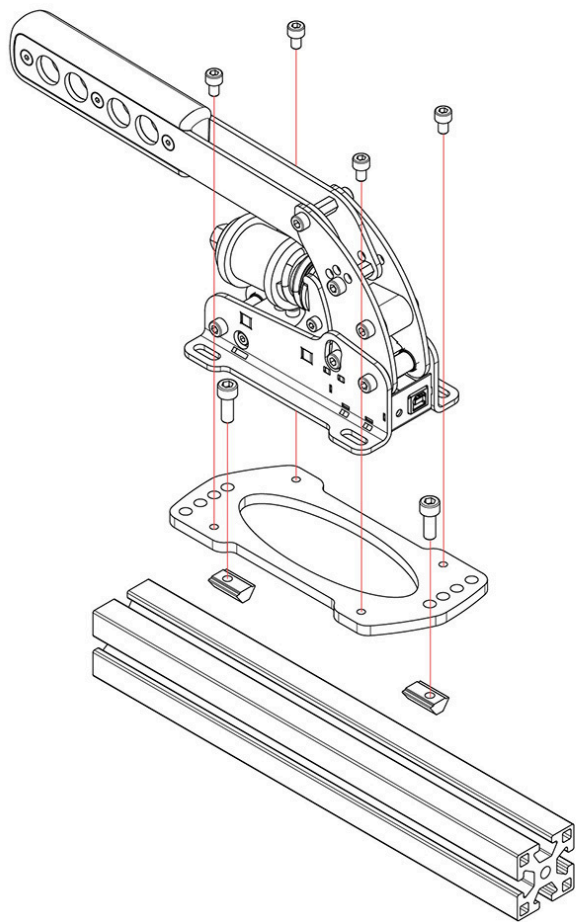

Yaw adjustment on the adapter plate

The adapter plate has a 22,5 degrees yaw adjustment.

Adjust the yaw of the handbrake by choosing different holes to bolt the adapter plate to your simulator.

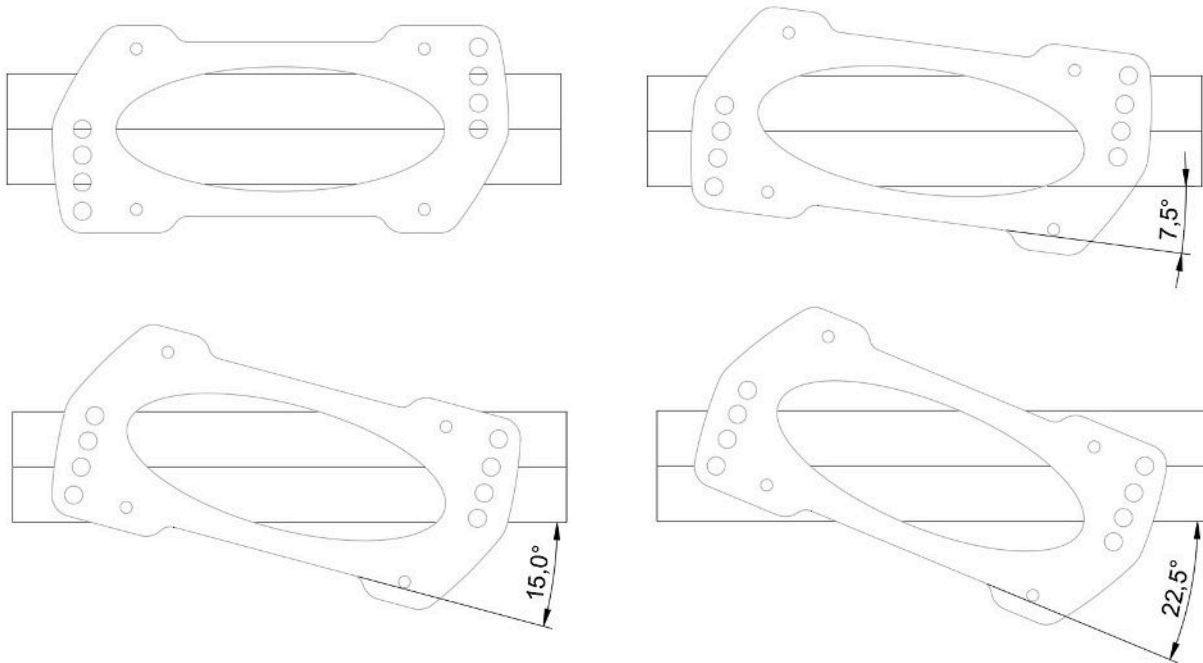

-13 -6.5 0 +6.5 +13

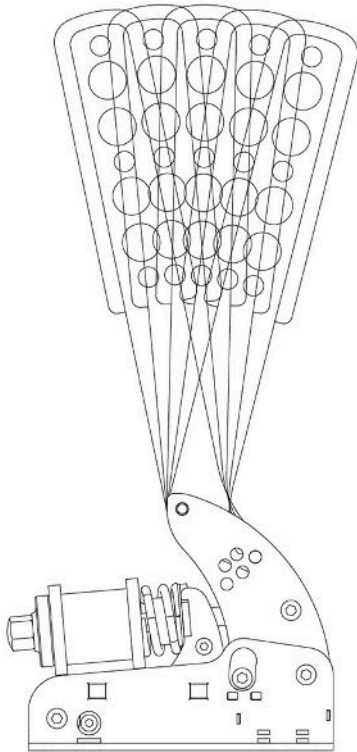

Fine-tuning the position of the lever

There is also an option to fine-tune the angle of the lever. In the vertical position you have 26 degrees of freedom. In the horizontal position you have 19,5 degrees of freedom (the lowest position can't be used when the lever is horizontal).

In order to fine tune the position of the lever, adjust the position of the lever mounting bolt closest to the base.

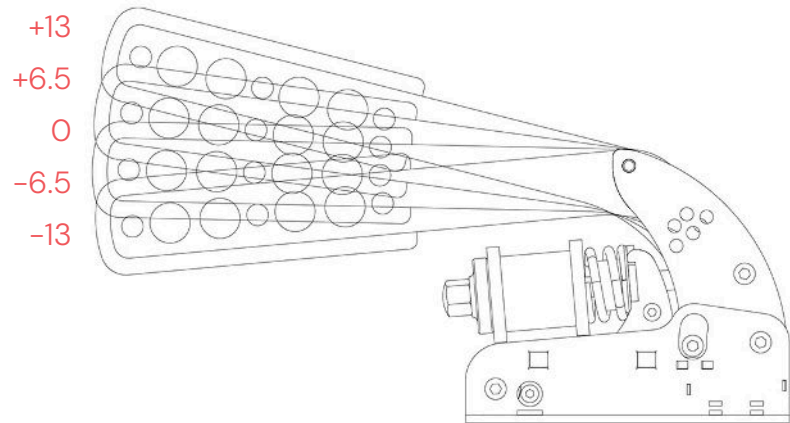

Connecting the electronics

We've provided a USB-cable with the handbrake. The controller board of the handbrake is integrated inside the base. One side of the USB-cable can be plugged into the handbrake. The other side should be connected directly to your pc.

Please make sure there is always a bit of slack in the cable. This prevents damage to the plug, socket and electronics. Specifically if you use a motion simulator, secure the USB cable to the (moving) frame of your simulator before you connect it to your handbrake.

Plug and play

Your handbrake is now ready for racing. It is pre- calibrated with a force of approximately 15 kg and it will work after assigning it in your favorite simulator software. Please note that iRacing requires an additional one-time in-game calibration: calibrate the handbrake to an output of 4095.

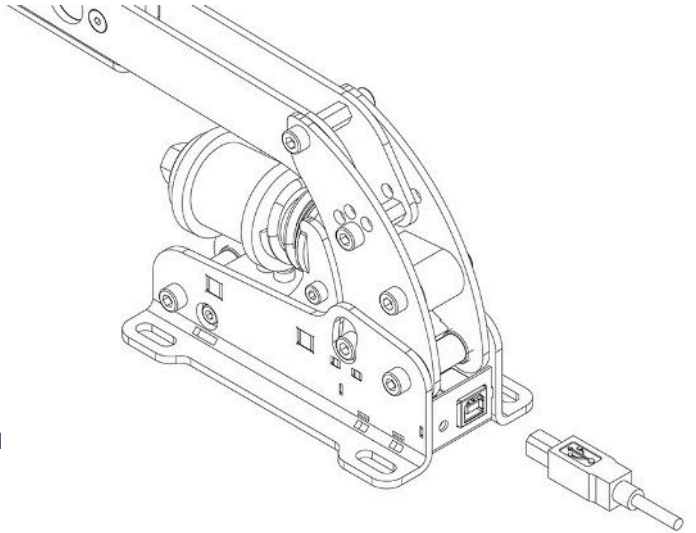

Mechanical adjustments

The Heusinkveld® Handbrake offers plenty of mechanical adjustments which change the mechanical feel of this product.

Principle of operation

The Heusinkveld® Handbrake is force based. The harder you pull, the higher the signal output to the simulator software will be.

It has a spring stack with a 2-stage system. Initially a metal coil spring is compressed. This coil spring simulates the pad-to-disc gap and/or the slack on the handbrake cable. The main loading of the brake disc is simulated by compressing the elastomers.

By adjusting the handbrake deadzone in SmartControl you have the option to let the brake signal output start as soon as you compress the metal coil spring, or only after the metal coil spring has been fully compressed.

The following adjustments are available:

- Resistance of the main elastomers (overall resistance)
- Travel on the metal coil spring.
- Preload on the metal coil spring.

Adjusting the overall resistance

Your handbrake has been supplied with 3 elastomers. One is already installed in the spring stack, the other 2 are in the accessory box. By changing the elastomer you can change the overall resistance of the handbrake.

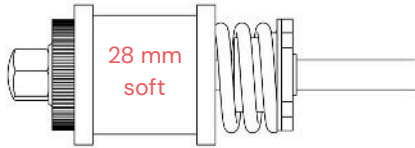

28 mm soft elastomer (softest option)

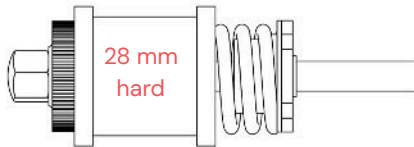

28 mm hard elastomer (default)

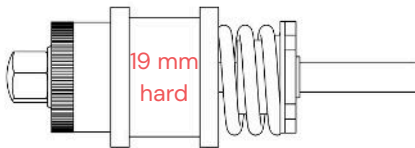

19 mm hard elastomer (hardest option)

- 28 mm soft elastomer (softest option)
- 28 mm hard elastomer (default)
- 19 mm hard elastomer (hardest option)

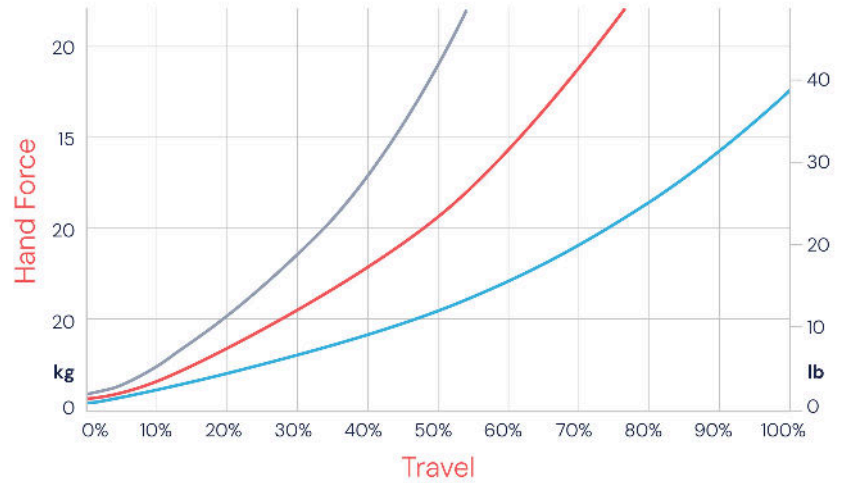

The top stack has the lowest resistance. The bottom stack has the highest resistance. By default your handbrake is set up with a medium resistance.

A small wrench is supplied with your handbrake to remove the end-cap of the stack. The required parts to build any of the above stacks are included.

Please note that changing the elastomer does not change the amount of force required to reach maximum output on the handbrake. The required amount of force can be changed through the SmartControl software.

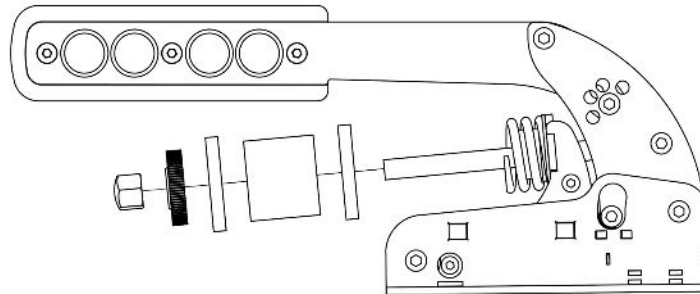

Adjusting the travel on the metal coil spring

Adjusting the travel on the metal coil spring

The handbrake is fitted with a metal coil spring. This metal coil spring simulates typical handbrake system slack. This slack may exist in a system where a brake pad is moved by hydraulics and needs to grip on a disc, or from slack in a cable based system.

The amount of travel in this metal coil spring can be varied by changing the length of the spacers inside the metal coil spring. At minimum the 10mm spacer should be present inside the spring. In order to shorten the travel, you can add 1-3 additional small spacers.

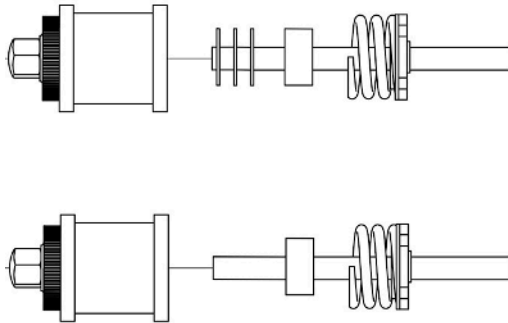

Removing the metal coil spring

If you don't want to use the metal coil spring, you have the option to remove it completely.

Adjusting the preload on the spring stack

You can change the preload on the spring stack using the knurled knob. Always make sure the end-cap sits against the knurled knob after adjusting.

By increasing the preload, you need a higher initial force to get movement in the lever. As a side effect the spring stack (mainly the metal coil spring) will compress a bit, resulting in a slightly lower travel.

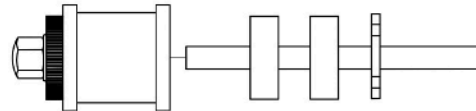

Smartcontrol Adjustments

The Heusinkveld® Handbrake comes with a powerful configuration tool allowing to set up your handbrake in ways not previously possible: SmartControl.

Download SmartControl

The software can be downloaded from our website heusinkveld.com. Click on Support (top bar). Scroll to Sim Handbrake. Click on Download SmartControl. Save the file and run from a folder of your choice.

Overview

With SmartControl you can configure (non-linear) handbrake output curves, set pedal deadzones and the brake pedal force. All settings can be saved into profiles, which can be loaded again in a few mouse clicks.

Settings applied in SmartControl will have effect in any simulator software, without having to make additional adjustments, re-assign controls

or recalibrate (including iRacing) in the simulator software itself.

Calibration

SmartControl also includes a calibration wizard. Because your handbrake has been pre-calibrated during assembly, calibration is not required before first use. Recalibration in SmartControl is only required when you have made mechanical adjustments to the spring stack.

Bottom deadzone adjustment

You can set a bottom deadzone for the handbrake in SmartControl. If you increase the deadzone, the handbrake lever requires a bit of force/movement before it registers output. The effect of your deadzone setting can be checked in realtime in the green vertical signal output bar.

Handbrake force setting

SmartControl allows you to set a maximum force on the handbrake. This setting is in kilograms (kg) and

represents the actual force pulled on the handbrake lever. The maximum brake force is 22kg. When you pull the maximum force on the handbrake, the handbrake will give 100% brake output signal to the simulator software.

Depending on which elastomers are installed in the rubber stack, you may reach the end-stop of the handbrake before reaching the maximum handbrake force. We strongly recommend setting a maximum handbrake force which can be achieved without having to pull the lever into the end-stop.

How you set the maximum handbrake force further depends on your personal preference. Even in similar real race cars, the required handbrake force varies a lot as this is a function of the specific components installed in that car.

Handbrake output mapping

A key feature of SmartControl is the ability to set a custom signal output map for your handbrake. Traditionally race simulator controller output has had a one-on-one sensitivity in relation to the handbrake

input. SmartControl allows you to map non-linear output curves using 5 zones (six input parameters).

The handbrake has a Curve Type pull-down menu with pre-defined output curves. Here you can also select the option to make a custom curve and then set the desired pedal output percentage at the 0%, 20%, 40%, 60%, 80% and 100% marks of the pedal input. You have complete freedom to set your own shapes.

Please note that some simulator software offers in-game options affecting the linearity of certain pedal outputs. In order for SmartControl to work effectively, always make sure that all in-game settings are set linear.

We will illustrate this functionality with a few use cases on the next pages:

Use case 1: Handbrake curve on a low grip surface. Rear wheels tend to lock up earlier on low a low grip surface such as gravel (for example at 50% handbrake output). By setting a convex output curve you can increase the useful range of the handbrake. You'll now effectively have a broader range for fine modulation before it reaches 50% output and the wheels are fully locked.

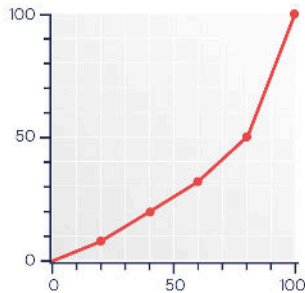

Case 1

Use case 2: Handbrake curve on a high grip surface. Rear wheels tend to lock up later on a high grip surface such as tarmac (for example at 80% handbrake output). By setting a concave output curve you can more easily reach full rear wheel lock, which may help you to better navigate hairpins on tarmac.

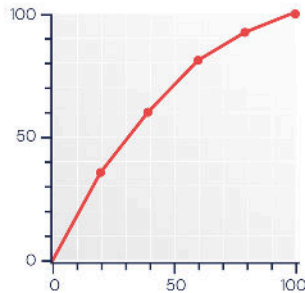

Case 2

Use case 3: Immediate lock for drifting. In drifting competitions instant lock of the rear wheels may be required. By setting a very aggressive output curve, instant lock can be achieved at even the slightest pull at the handbrake lever.

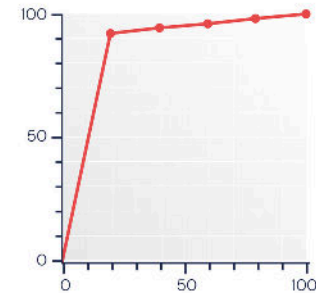

Case 3

Using SmartControl with iRacing

The handbrake sensor output value always ranges from 0–4095, regardless of your settings in SmartControl. Most simulator software can instantly use these output values, because Windows works with a default range of 0–4095 for 12bit USB devices as well.

A notable exception is iRacing, because iRacing uses an in-game method to calibrate the handbrake. In order for the Sim Handbrake to function correctly in iRacing, you must do the following:

When using the handbrake calibration wizard in iRacing, you will see a RAW value. When asked to pull the handbrake, make sure you always pull it to a value of 4095.

This ensures that your SmartControl settings always function correctly in iRacing. You will only need to calibrate in iRacing once. Re-calibration after changing SmartControl settings is not required.

iRacing offers the optional setting 'custom controls for this car'. If you use this setting, always make sure to follow the instructions 1 and 2 per car in order for your SmartControl adjustments to function correctly in iRacing.

Save and Load profiles

SmartControl allows you to store an unlimited amount of profiles. In order to save a profile, click on File and then Save Profile. In order to load a profile, click on File and then Load Profile.

Shared profiles with other SmartControl compatible products If you have other Heusinkveld products which work with SmartControl, you can create shared profiles for multiple devices (for example a profile which includes settings for a handbrake + pedal set).

When loading a profile you have the option to load specific elements of a shared profile (for example only load the profile settings of the handbrake and not for the pedals).

Good to know

All profiles are saved relative to your personal calibration values. This means that you can exchange profiles with fellow Sim Handbrake owners and apply them without re-calibrating.

Profile changes are applied directly onto the handbrake controller board. If your simulator software is Alt-TAB friendly, you can apply a different profile or test specific adjustments in the middle of a training session.

Maintenance

The Heusinkveld® Handbrake has been designed to have a minimum of wear, tear and noise. Please take note of the following in order to keep your product in good shape for many years.

Preventive maintenance

The Sim Handbrake has been designed to not require any preventive maintenance. All pivot points contain self-lubricating bearings and the elastomers have minimal friction relative to other parts of the spring stack.

Elastomers

After very prolonged use (tens of thousands of duty cycles) the elastomers may leave a small amount of dust-like residue. This can safely be wiped away with a dry cloth. The performance of the elastomers will not be affected: These have been tested to retain their as-new characteristics even after one million duty cycles in an overload situation.

Recommended lubricant

If you do feel the need to lubricate parts of your handbrake, the recommended lubricant is PTFE Dry Spray. Under normal circumstances this should not be necessary.

Support

If you need any help, please send us an email at support@heusinkveld.com.

Safety

Please take note of the following when using the Heusinkveld® Handbrake.

General product description and intended use

The Heusinkveld® Handbrake is a sensor-based handbrake system with a lever that can be connected to a computer for use in a driving simulator.

The product is suitable for use in a simulator only. The product is not suitable for use on (public) roads, on a test track, or as part of an electric vehicle.

Safety precautions

No specific personal safety equipment is required to use this product.

The product must be mounted rigidly to the simulator. When driving, the seat of the simulator and the product must not be allowed to move freely relative to each other.

Recycling & environment

The packaging of the Heusinkveld® Handbrake is made out of paper and cardboard where possible. Please use the appropriate paper waste stream to dispose the packaging in case you don't want to keep it.

At Heusinkveld we support our products with spare parts for many years after the original production date. In the very unlikely case the product itself needs to be scrapped, please make sure to follow local guidelines for responsible recycling.

If you need to disassemble the product, please use the provided hex keys to do so. This allows you to separate the various materials used in the product.

If you are unsure how to responsibly recycle the product, you may always send it back by mail to Heusinkveld:

Heusinkveld Engineering
Cuxhavenweg 5E
9723JK Groningen The Netherlands

CE Declaration of Conformity

EU DECLARATION OF CONFORMITY (No. 2021/947-02)

This Declaration of Conformity is issued under the sole responsibility of the manufacturer.

MANUFACTURER

Company name	Heutsinkveld Engineering B.V.
Full address	Cuxhavenweg 5E
Postal code	9723 JK
Place	Groningen
Country	The Netherlands

IDENTIFICATION OF APPARATUS

(Commercial) name	Sini Handbraike
Function/intended use	Sensor based handbraike for driving simulator
Type/model	Handbraike V2
Batch/serial	HE-HBv2

The object of the Declaration described above is in conformity with all relevant provisions of:

**EMC Directive 2014/30/EU; RoHS Directive 2011/65/EU;
General Product Safety Directive 2009/95/EC**

In conjunction with the following relevant harmonised standards or technical specifications:

**EN 55032:2015/AC:2016; EN 55024:2010; EN 55016-2-3:2017; EN-IEC 61000-4-2:2009;
EN-IEC 61000-4-3:2006+A1:2008+A2:2010; EN IEC 63000:2018; EN ISO 12100:2010**

Signed for and on behalf of:

Place of issue:	Groningen The Netherlands	Identity:	Mr. Svend van der Vlugt CEO
Date of issue:	20 January 2022	Signature:	

Welcome to Heusinkveld



WILLIAMS / **ESPORTS**
OFFICIAL SUPPLIER